

MITSUBISHI A6M3 ZERO FIGHTER

(HAMP)

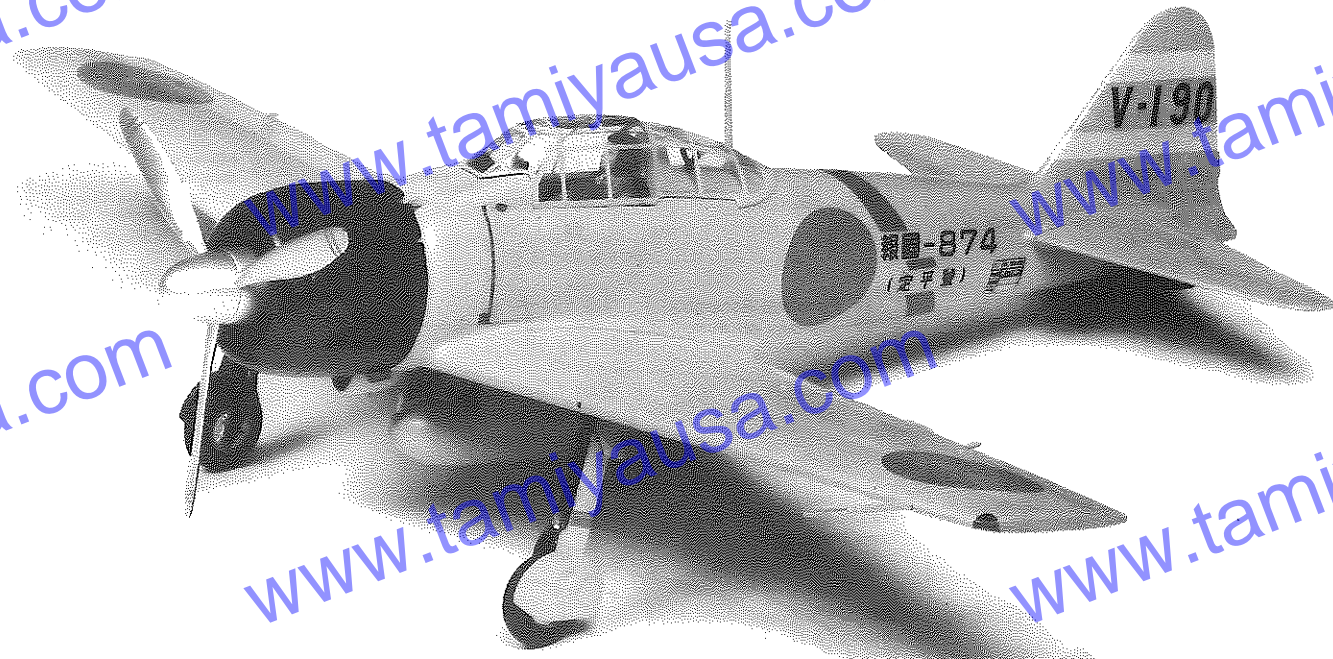

Much has been written over the years about the Japanese Zero Fighter Aircraft series. Much was based upon hearsay and legend and little upon fact itself. Even the Allied Forces and governments refused at first to acknowledge its existence, and when they did get a copy of it, they could hardly believe the performance it produced. The prototype zero or A6M1 first took place on paper on January 17, 1938, following the Japanese request for a shipboard fighter with a top speed of 270 kph at 12000 ft & 6-8 hours of cruise

Zero Type 21

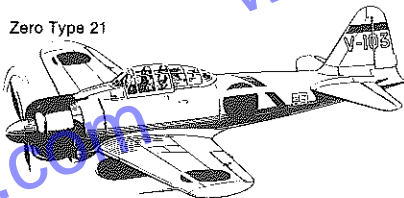

economy endurance and 1.5-2 hours at normal combat speeds. Armament was to be two 20 mm cannon and two 7.7 mm machine guns plus the normal radio equipment and direction finding gear. These specifications were so far from the existing state of the art that the famous Nakajima Company dropped out of competition, stating that they were impossible to meet. That left Mitsubishi Heavy Industries and their design team headed by Jiro Horikoshi the only company to tackle the problem. First flight was on 1 April 1939 and combat trials were concluded in July 1940 with 15 pre-production A6M2's sent to two squadrons by the end of the month. These aircraft had folding wing tips to accommodate aircraft carrier elevators, and were the ones first seen by Gen. Chennault in China, and at Pearl Harbor in December 1941. Although the A6M2 met or exceeded original design specifications, modifications were taking place at the Mitsubishi factory to improve roll rate, speed up handling aboard carriers, and utilize the uprated Sakae 21, 1,130 hp

engine. The first A6M3 type 32 (code named HAMP) took to the air on 15 July 1941 with production beginning in April 42. A total of 343 aircraft were produced by August 43, when the type 52 A6M5 began production. The Type 32 Zero had the most radical change in the entire series and was readily recognized by its squared off wing tips. This reduced total span to exactly 11 meters and eliminated the cumbersome folding tips which consumed time during combat to get the aircraft down carrier elevators. The larger Sakae 21 engine gave the type 32 a better rate of climb and the shorter wing span (1 meter shorter) lessened stick forces and increased roll rate. The Hamp was utilized throughout the war, but saw most of its service off of land based installations in the southern island chains of New Guinea and the Phillipines.

In den vergangenen Jahren wurde vieles über den japanischen Zero Fighter geschrieben, das meiste basierte auf Hörensagen und Legenden, aber nur wenig auf Tatsachen. Sogar die Allied Forces und Regierungen wollten die Existenz dieses aussergewöhnlichen Flugzeuges nicht zur Kenntnis nehmen. Als sie dann ein Flugzeug dieser Type in die Hände bekamen, konnten sie die Flugleistungen kaum glauben. Es wurde von den japanischen Streitkräften ein Bordflugzeug verlangt, welches 270 km in der Stunde in 12000 feet Höhe erreichen konnte und 6 bis 8 Stunden in der Luft blieb, bezw. 1-1/2 bis 2 Stunden bei normaler Kampfgeschwindigkeit. Die Pläne für den ersten Prototyp Zero oder A6M1, konnten bereits am 17. Januar 1938 vorgelegt werden. Bewaffnung waren zwei 20 mm Kanonen und zwei 7,7 mm Maschinengewehre, normale Funkausrüstung mit Peilempfänger. Dieses Verlangen war von dem damaligen Stand der Entwicklung soweit entfernt, dass sogar die bekannten Nakajima Werke sich vom

Angebot zurückzog mit dem Bemerken, es wäre unmöglich, diese Wünsche zu erfüllen. Somit blieb nur das Team Jiro Horikoshi von Mitsubishi übrig, um dies Problem zu lösen. Und dies Problem wurde von diesen Leuten gelöst, der erste Flug war am 1. April 1939, Kampferprobung erfolgte im July 1940 mit bereits 15 Vorseerienflugzeugen. Diese Maschinen hatten klappbare Flügelenden, um in die Flugzeugträger-Aufzüge zu passen. Es waren die Flugzeuge, die man zuerst bei Gen. Chennault in China und in Pearl Harbor im Dezember 1941 sehen konnte. Natürlich wurden von Mitsubishi an der A6M2 laufend Verbesserungen vorgenommen, z.B. wurde der verstärkte Sakae 21 Motor mit 1.130 PS eingebaut um die Startgeschwindigkeit auf den Trägern zu erhöhen. Der erste A6M3 Type 32 (Codename HAMP) ging am 15. July 1941 in die Luft, die Pro-

Zero Type 52

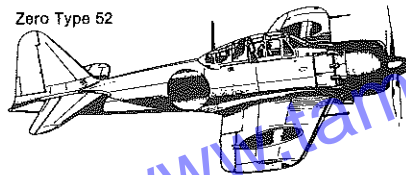

duktion begann im April 1942, bis August 1943 wurden 343 Maschinen gebaut, dann folgte der Type 52 A6M5. Der Type 32 Zero hatte die grössten Änderungen der ganzen Serie, man konnte den neuen Type 52 sofort an den rechteckigen Flügelenden erkennen. Diese Änderung brachte die Spannweite nunmehr genau auf 11 Meter, es konnte das umständliche Abklappen der Flügelenden wegfallen und es wurde viel Zeit beim Transport mit den Trägeraufzügen gespart. Der grössere Sakae 21 Motor gab dem Type 32 eine bessere Steigleistung, die kürzer Spannweite (-1 m) verringerte die Steuerkräfte und erhöhte die Startgeschwindigkeit. Der HAMP war bis Kriegsende im Einsatz, hauptsächlich auf Landbasen der südlichen Inselketten New Guenia's und auf den Phillipinen.

★ Study the instructions and photographs before commencing assembly.
 ★ You will need a sharp knife, a screwdriver, a file and a pair of pliers.
 ★ Do not break parts away from sprue, but cut off carefully with a pair of pliers.
 This mark denotes paint color, and the color names and numbers are for Tamiya Acrylic Paints

★ Vor Beginn die Bauanleitung studieren und den Nummern nach die Elemente zusammenbauen.

★ Bauteile nicht vom Spritzling abbrechen, vorsichtig abschneiden oder abzwickeln.

Dieses Zeichen zeigt die Farbe und Farbnummer der Tamiya Acryl Farben.

1 «Cockpit Detailing» «Cockpit»

Drill out seat back indentations with a 0.9mm drill. Seat belt and harness is painted masking tape.

Die Einkerbungen der Rückenlehne mit 0,9mm Bohrer einbohren. Sitzgurt wird aus bemaltem Abdeckband hergestellt.

Drill Holes

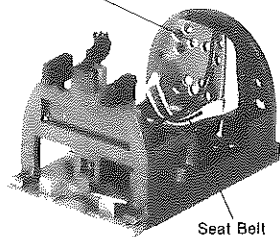

Seat Belt

Decal (C) Abziehbild
 Decal (P) Abziehbild
 Decal (R) Abziehbild

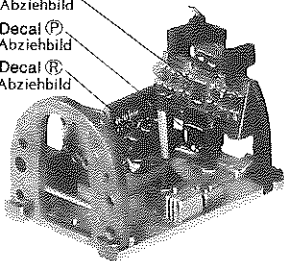

4 «Engine Detailing» «Sternmotor»

Pushrods are stretched sprue 5.4mm long and 0.4 in dia. (28 req) Attach to, and below, projecting pins on front cylinder bank and to rocker boxes on rear bank. Fine copper wire is used for ignition and runs from 14 0.2mm holes drilled in ignition ring, two wires per hole. Front bank wiring runs up front cylinders right pushrod and into .02mm holes drilled in each head, front and rear. Rear bank wires run up left pushrod. (total of 28 wires secured in place with cyanoacrylate)

Oil tubing runs between each cylinder rockerbox, on opposite side from pushrods. Use 0.4 mm stretched sprue.

Es werden 28 Ventilstößel aus Plastikabfall 5,4mm lang und 0,4mm Ø gezogen. (über Kerze wärmachen und drehen bzw. auseinanderziehen) Diese Ventilstößel werden an der vorderen und hinteren Zylinderbank an die vorstehenden Zapfen angeklebt.

Für die Zündung wird feiner Kupferdraht genommen. Aus den 14 Löchern (0,2mm) gehen je 2 Drähte am Zündungsring heraus. An den vorderen Zylindern rechts am Ventilstößel vorbei in das Loch am Zylinderkopf. Die hinteren Drähte gehen am linken Ventilstößel vorbei. Die Drähte mit Bombenkleber befestigen. Ölschläuche werden aus 0,4mm Abfall gezogen und auf der anderen Seite der Ventilstößel zwischen jedem Zylinder angeklebt.

Push Rods

Plug Wire

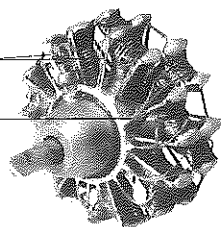

1 Cockpit Assembly Zusammenbau der Cockpit

★ Refer to left photo for applying decals.
 ★ Linkes Foto für Anwendung der Abziehbild sehen.

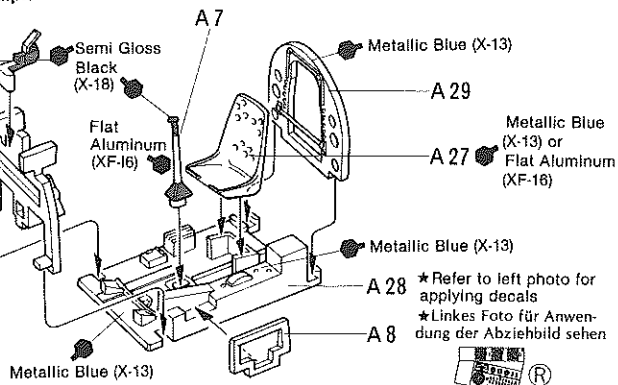

2 Fuselage Assembly Montage der Rumpfhälfte

Cockpit Interior; Metallic Blue (X-13)
 Innere Wand

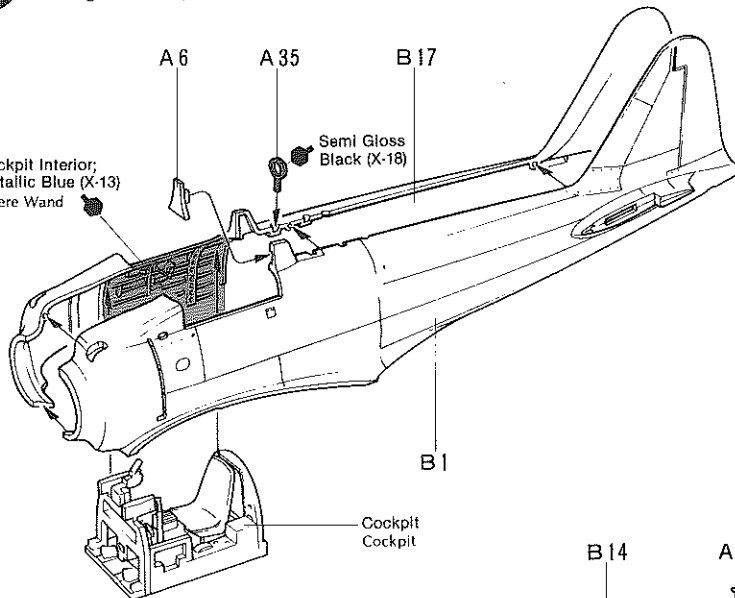

3 Main Wing Assembly Montage der Tragflächen

«Attaching A11»
 «Einbau A11»

Front Vorder

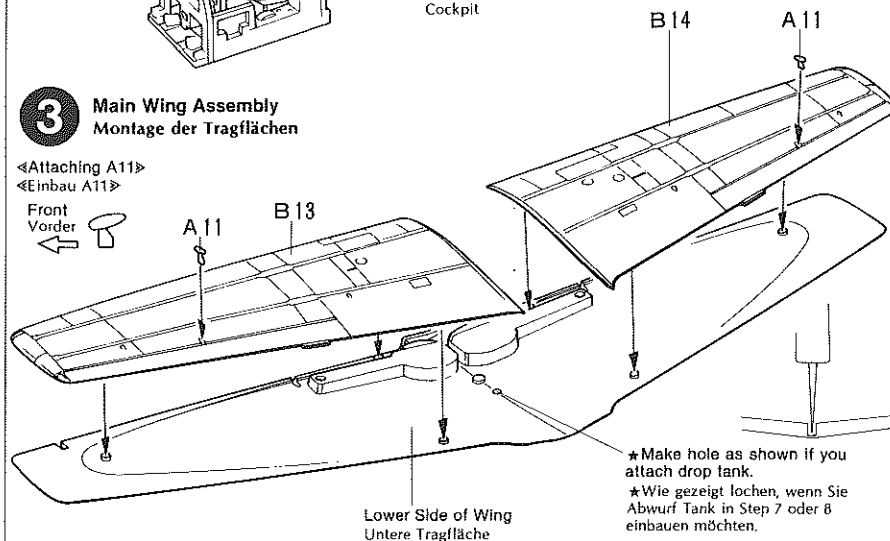

★ Make hole as shown if you attach drop tank.
 ★ Wie gezeigt lochen, wenn Sie Abwurf Tank in Step 7 oder 8 einbauen möchten.

4 Engine Assembly Motorenbau

Gun Metal (X-10)
 Flat Aluminum (XF-16)
 Medium Grey (XF-20)

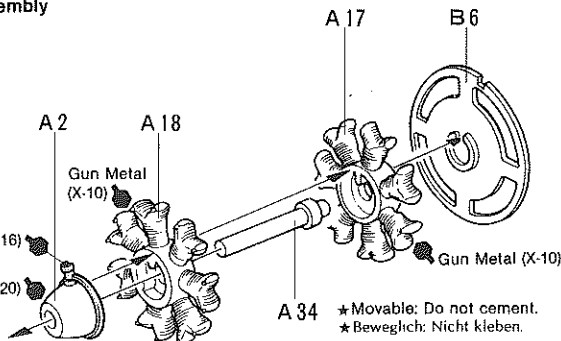

★ Movable: Do not cement.
 ★ Beweglich: Nicht kleben.

6 <Landing Gear Detailing> <Fahrwerk>

Drill out and shape oleo strut scissors (top) and cut away center portion of main gear door attachment bars. Run copper wire (brake tubing) from wheel well, down between center of gear door and strut, thru top scissors and fasten at moulded fitting on wheel. Small gear doors attach to wing and rest on main doors at an acute angle. See drawing.
Zwischen Fahrwerkstrebe und Verkleidung wird ein Kupferdraht als Bremsleitung gelegt.

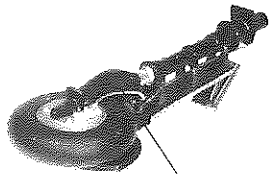

Brake Oil Pipe
Bremsölschlauch

Cut a groove to attach
brake oil pipe
Einzubauen Bremsölschlauch
nuten

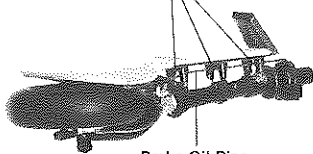

Brake Oil Pipe
Bremsölschlauch

7 <Lower Surface Details: Gear Down> <Zusammenbau der Unterseite>

<Drop Tank Assembly>
<Abwurf Tank Einbau>

B 16

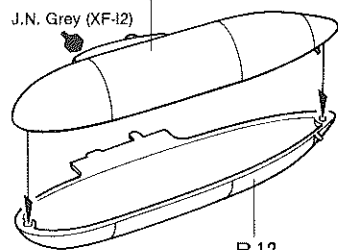

<Main Gear Positioning>
<Stellung der Fahrgestelle>

<Left Gear>
<Links>

<Right Gear>
<Rechts>

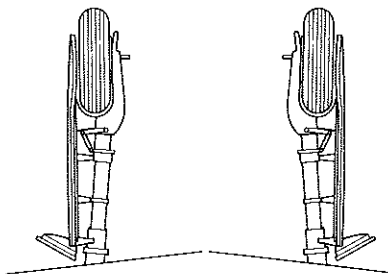

★ Gear struts angle inwards slightly.
★ Fahrgestellstreben sind etwas nach innen geneigt.

Tamiya Acrylic Paints

Need precise colour matching?
Try the new Tamiya acrylic
paints. Engineered by modelers for modeler's use. The final cover for the finest models. Insist on Tamiya for perfect results.



TAMIYA COLOR CATALOGUE

The latest in cars, boats, tanks and ships. Motorized, radio controlled and museum quality models are all shown in full color in Tamiya's latest catalogue. At your nearest hobby supply house.

5 Main Wing Attachment Montage der Tragflächen

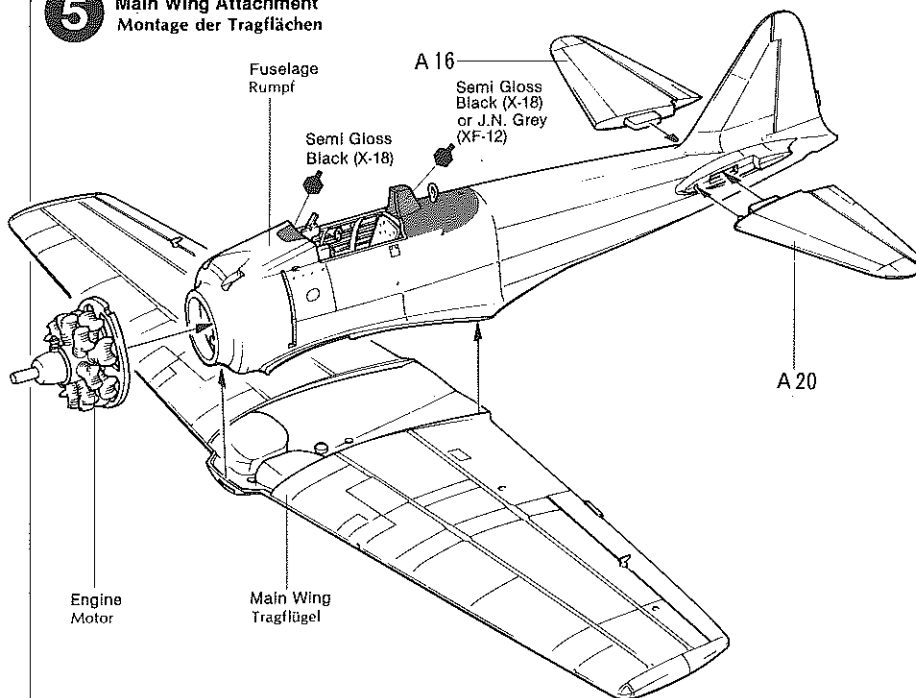

6 Landing Gear Assembly Fahrgestell

<Left Gear>
<Links>

Semi Gloss Black
(X-18)

<Right Gear>
<Rechts>

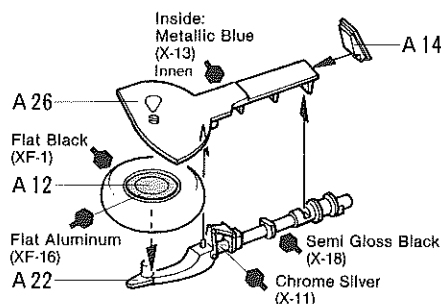
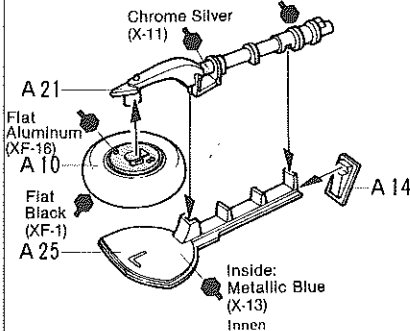

7 Under Surface Details: Gear Down Zusammenbau der Unterseite (Ausgefahren)

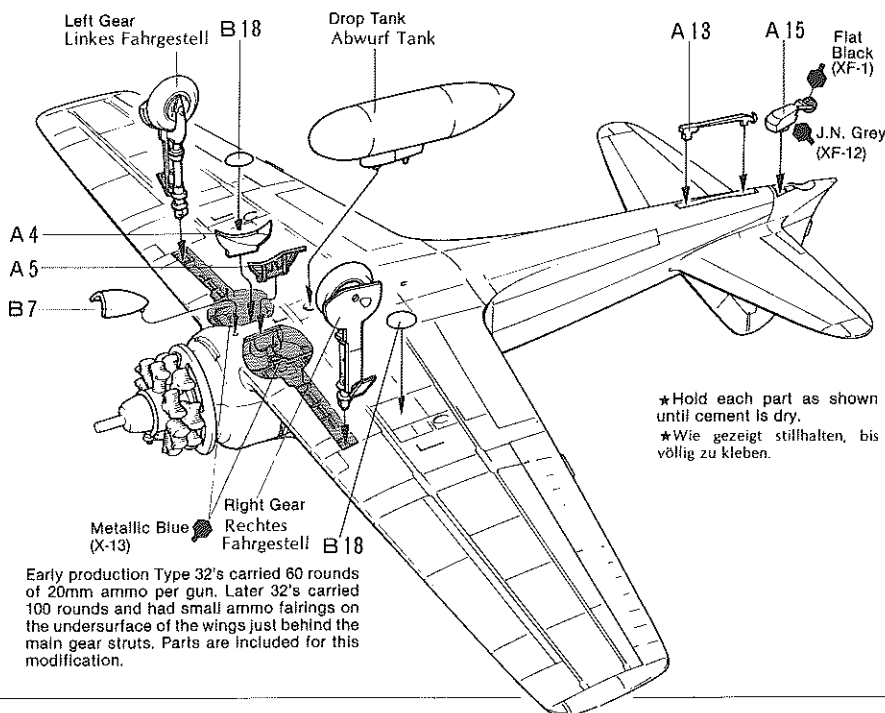

★ Hold each part as shown
until cement is dry.
★ Wie gezeigt stillhalten, bis
völlig zu kleben.

Early production Type 32's carried 60 rounds of 20mm ammo per gun. Later 32's carried 100 rounds and had small ammo fairings on the undersurface of the wings just behind the main gear struts. Parts are included for this modification.

«Figures»
«Figuren»

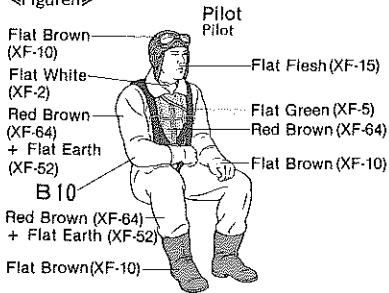

Petty Officer
Maat

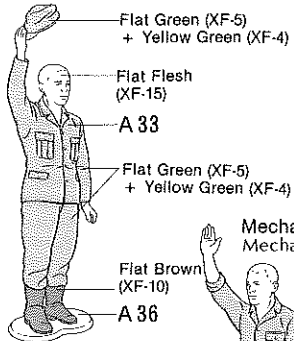

Mechanic
Mechaniker

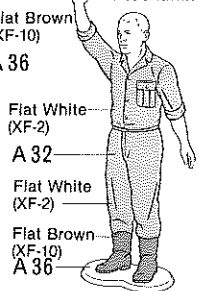

Mechanic
Mechaniker

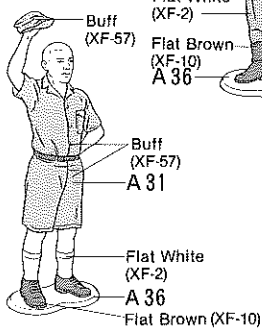

«Propeller Assembly»
«Propeller»

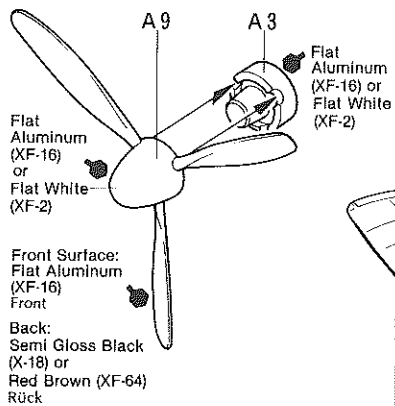

Engine Cowl:
Do not cement.
Motorhaube: Nicht kleben.

Propeller: Do not cement.
Propeller: Nicht kleben.

*C5: Not used.
/Nicht nützen.

8 Under Surface Detail: Gear Up
Zusammenbau der Unterseite (Eingezogen)

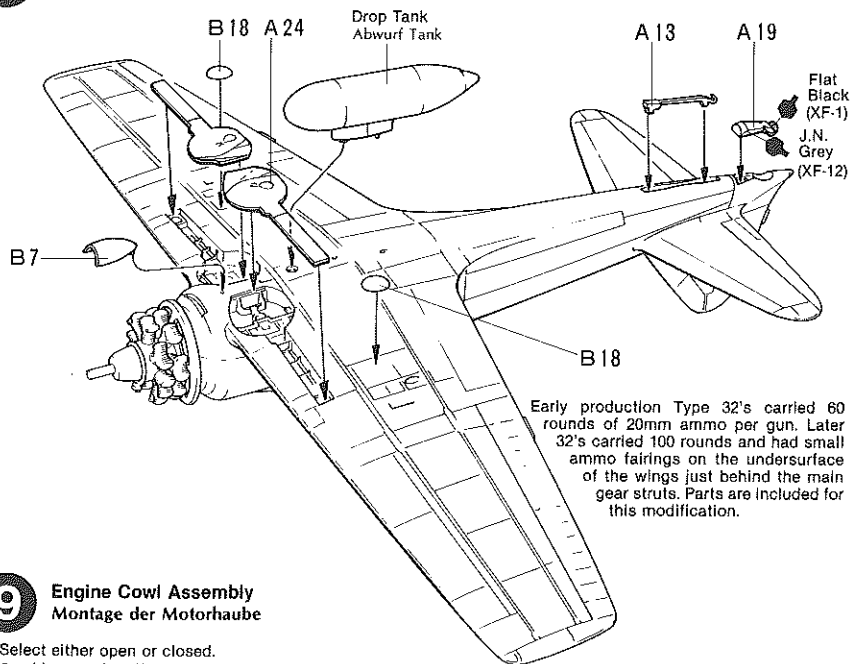

9 Engine Cowl Assembly
Montage der Motorhaube

*Select either open or closed.
*Geschlossen oder offen auswählen.

Cowl Flaps were open when engine was "run-up" on the ground; during taxiing, and during climb-out, to keep engine head temperatures in the green.

«Flap-closed»
«Geschlossen»

«Flap-open»
«Offen»

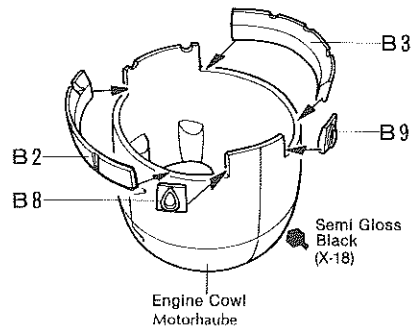
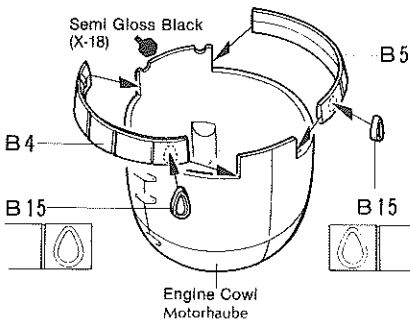

10 Attaching Canopy
Kanzel Einbau

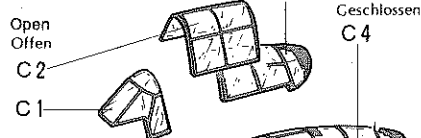

*Canopy: Select either open or closed.
*Kanzel: Geschlossen oder offen auswählen.

• Canopy Frame: body color.
• Kanzelrahmen: Wie Rumpf bemalen.

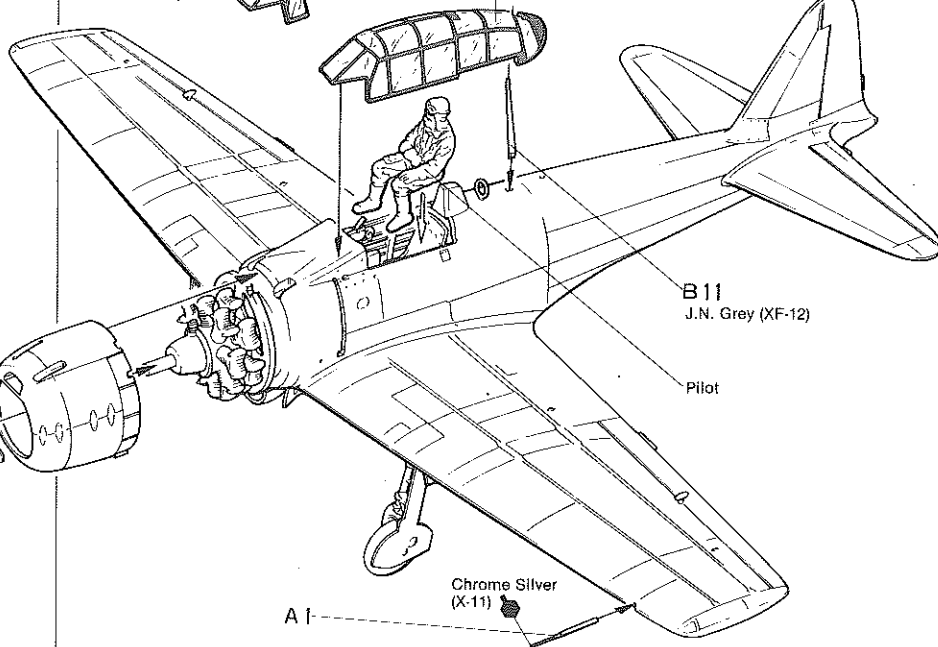

① 2 Fighter Group, Buna, East of New Guinea, 1940

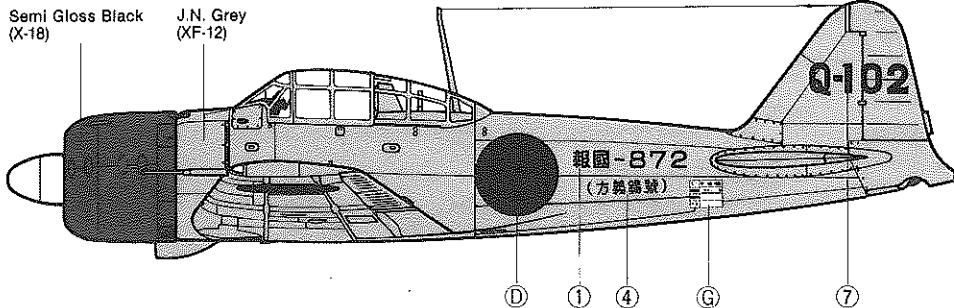

② Tainan Fighter Group (1st), Buna, East of New Guinea, 1942~43

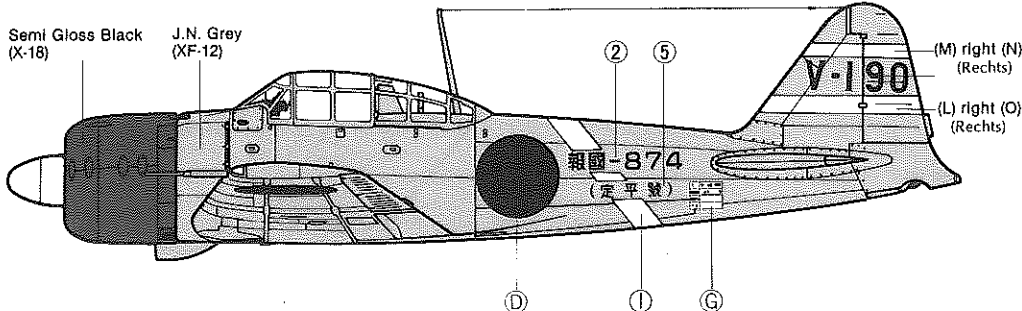

Painting of Type 32 «Earl»
 Engine cowling: Matt Bl...
 were a matt light grey.
 aluminum and rear was
 narrow red warning bar
 blade tip. No white band
 signia. This color scheme
 till the summer of 1943.

«Late Color Schemes»
 In July 1943, the Japanese
 directive that all aircraft utilized
 would be painted jungle
 and that an orange yellow
 ed on the leading edge
 root of the wing to half
 craft already in the field
 of jungle green. Some a
 border around the nation
 exception, rather than a
 black.

Interior of all A6M series
 preservative paint metal
 Japanese, called "Blue E"

«Detail Painting»
 Engine cylinders. Alumini
 very thin matt black to be
 grey. Pushrods, wiring a
 tion ring: aluminum. Prop
 dark red brown. Spinner:
 a matt black, not flat or gl
 faces (cockpit etc.) were
 preservative, metallic bl
 than green.

Painting Example ①、②
 Bemalung

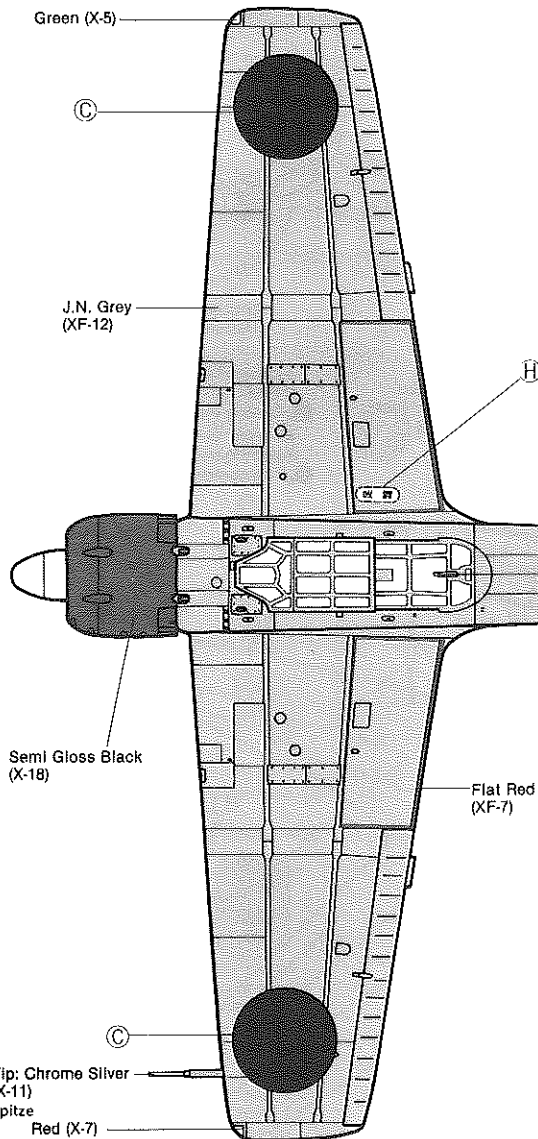

Painting Example ①、②
 Bemalung

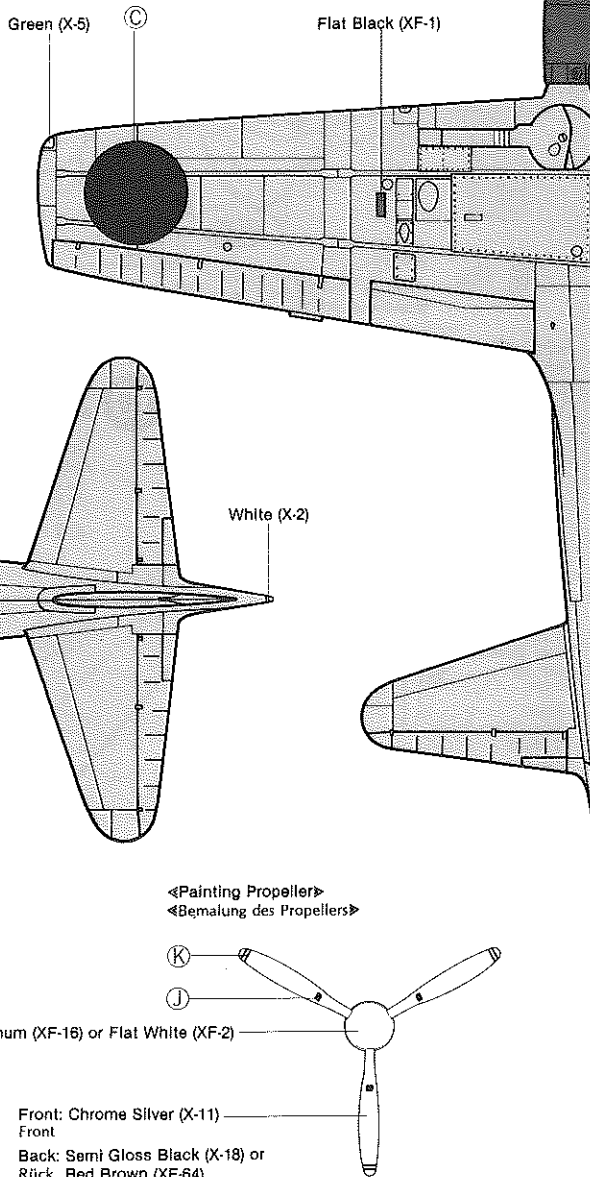

Color Scheme

ack. All other outer surfaces
Propeller front was polished
black or dark red brown. Two
ids were located near each
l surrounded the national in-
was seen on all Type 32's un-

re Government issued a direc-
ed in the South Pacific area
green on the upper surfaces,
w identification band be plac-
of each main plane from the
way out to the tip. Those air-
were painted over in blotches
ircraft are seen with a white
nal insignia; however, this is
rule. Cowlings remained matt

aircraft were protected with a
ic blue/green in color, and in
bamboo Color".

um. Finished with a wash of
ing out fins. Crankcase: Light
nd oil lines: gloss black. Igni-
eller: Front aluminum, rear is
aluminum or white Cowling is
lossy. All exposed interior sur-
painted with an anti-corrosive
ue/green in color. More blue

③ 204 Fighter Group, Rabaul, 1943, (Painted over in blotches of jungle green)

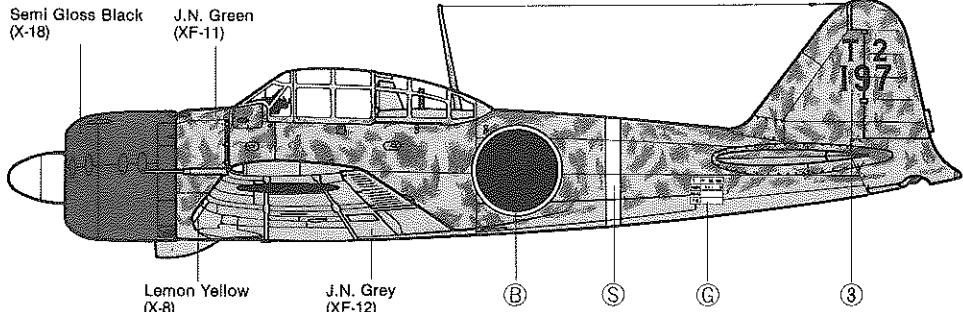

④ Tainan Fighter Group (2nd), Taiwan, 1944

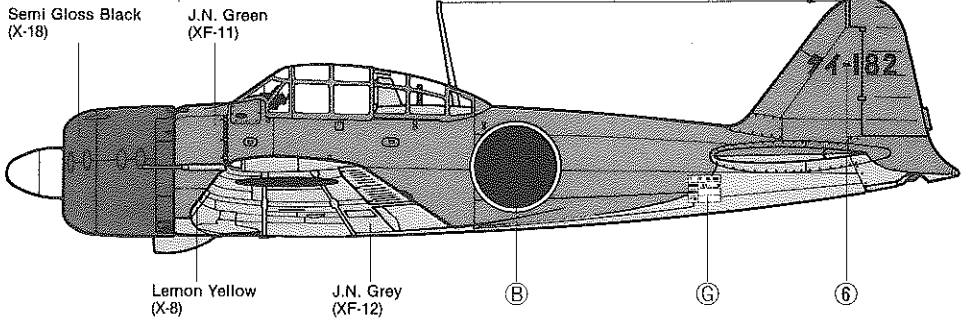

Painting Example Bermalung

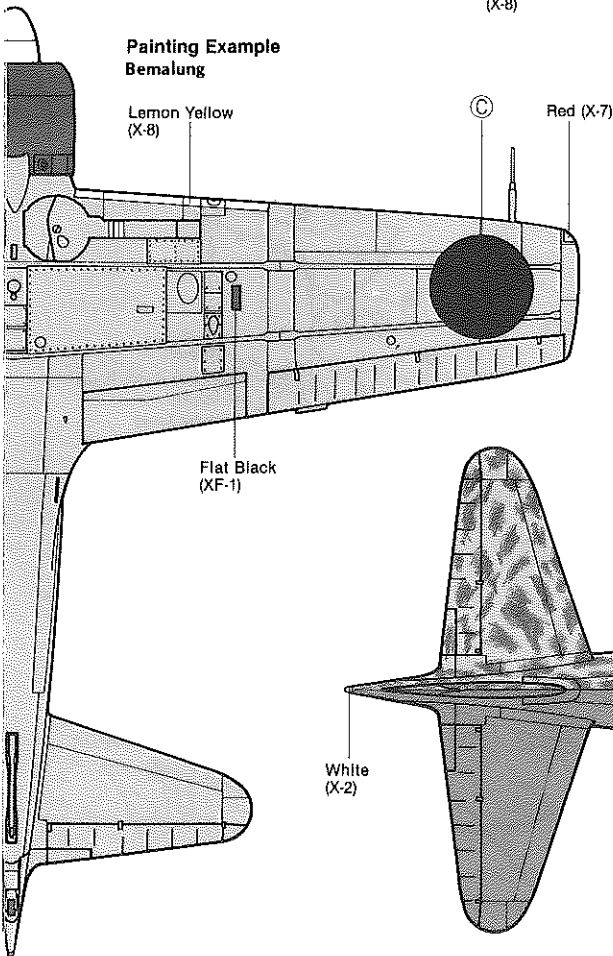

Painting Example ③ Bermalung

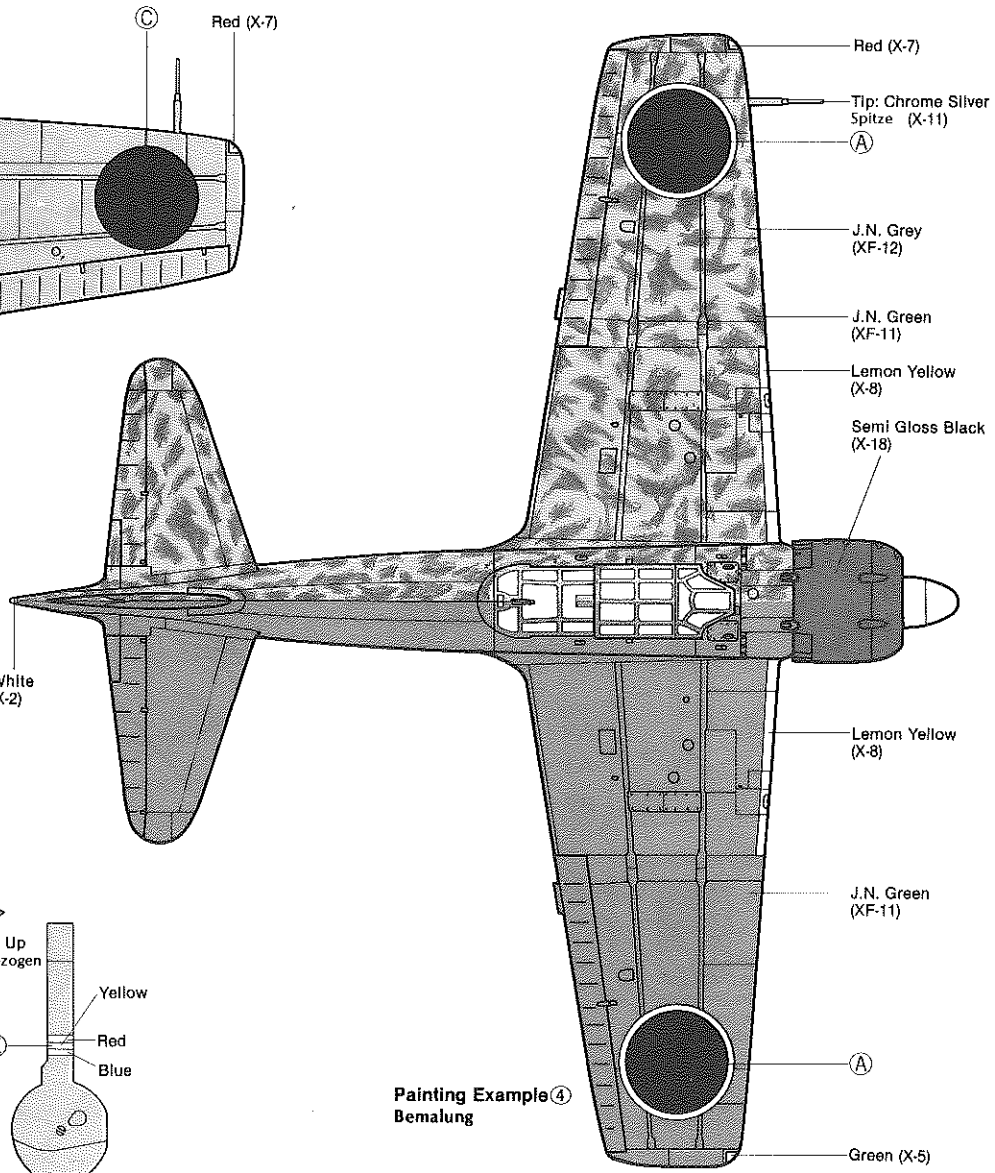

**«Marking on Gear Doors»
«Abziehbild der Fahrgestelle»**

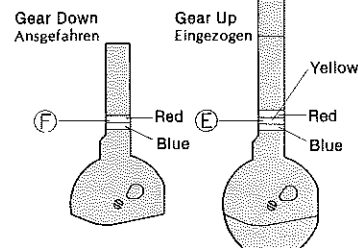

Painting Example ④ Bermalung